

Approved: 25.04.2022

Valid from: 25.04.2022

Edition: 2022-01

TENAX PANEL

SANDWICH PANELS

SELECTION, HANDLING AND INSTALLATION MANUAL

Contents

1.	General instructions.....	4
1.1.	Application	4
1.1.1.	Limitations to dark shades and matt coating surfaces	4
1.1.2.	Instructions for mechanical resilience calculations and assembly layout	5
1.1.3.	Panels without surface profile or with V-type profile.....	6
1.2.	Detailed elaboration	6
1.3.	Labour safety.....	6
1.4.	Nature protection	6
1.5.	Responsibilities and guarantees of the manufacturer	6
1.5.1.	Tonal consistency.....	7
1.5.2.	Corrosion resistance.....	8
2.	Transport and storage.....	9
2.1.	Package	9
2.2.	Panel supplies.....	9
2.3.	Unloading of panels	10
2.3.1.	Unloading of packages by lift trucks	10
2.3.2.	Unloading of packages with a crane	10
2.4.	Storage of panel packages	12
3.	Preparations for installation	14
3.1.	Devices and instruments.....	14
3.1.1.	Lifting devices.....	14
3.1.2.	Tools.....	14
3.2.	Building framework.....	15
4.	Lifting and moving of separate panels.....	16
4.1.	General instructions.....	16
4.2.	Lifting and moving panels manually.....	16
4.3.	Mechanical grippers.....	16
5.	General rules for installation	18
5.1.	Mechanical processing.....	18
5.2.	Interruption/prevention of thermal bridging	18
5.3.	Sealing of joints and places of fasteners.....	19
5.4.	Attachment	20
5.5.	Removal of protective film.....	21
5.6.	Panel cleaning	21

5.7. Provisions for the installation of dark panels.....	22
5.7. Provisions for the installation of metallic colour panels.....	22
6. Installation of external wall.....	23
6.1. Horizontal installation	23
6.2. Vertical installation	24
7. Installation of Profiled (Trapeze) Roof Panels.....	27
8. Installation of Roll-Folded Roof Panels	30

1. General instructions

TENAX PANEL General Terms and Conditions for the Sale of Goods or other sales document regulating the sales-transfer of sandwich panels is an integral part of this Manual.

1.1. Application

Sandwich panels TENAX W manufactured by TENAX PANEL are meant for the cladding of external and internal walls, and ceilings.

The sandwich panels TENAX TR manufactured by TENAX PANEL are particularly suitable for multiple roof solutions with the minimal inclination of 3°, if an overlap is not needed, and 5°, if a roof overlap is needed. It is allowed to use TENAX TR sandwich panels also for walls, especially in areas with increased wind loads.

The planned use of the sandwich panels is specified in the performance declarations of the relevant panels in more detail.

1.1.1. Limitations to dark shades and matt coating surfaces

A panel of any colour is heated by the solar radiation. The length of the heated covering layer is impacted the most. The temperature on the side heated by the solar radiation and inside the room can differ radically due to the heat insulation properties of the panel, so tension in the panel can be caused. The major panel deformations occur in buildings with a negative internal temperature, that is, in freezers.

According to the European standard EN 14509, the covering layers of sandwich panels are divided into three groups – of “very light” (group I), “light” (group II) and “dark” (group III) colours. Each colour group has its set temperature at which the load-bearing capacity of a panel is calculated according to its conditions of use.

Table 1. The division of colour tones by their heating under the direct sun radiation according to EN 14509:2014

Tone groups		Solar reflectance	The maximum surface temperature in summer	RAL examples
Group I	Very light	R _G =75-90	T ₁ =+55°C	1015, 1016, 1018, 6019, 7035, 9001, 9002, 9010
Group II	Light	R _G =40-74	T ₁ =+65°C	1002, 1003, 1004, 1014, 1017, 1019, 1021, 1023, 2000, 2003, 2004, 2008, 2009, 5012, 5018, 5024, 6018, 6021, 6033, 7000, 7037, 7040, 7047, 9006, 9022
Group III	Dark	R _G =8-39	T ₁ =+80°C	3000, 3002, 3003, 3005, 3009, 3011, 3013, 5002, 5005, 5009, 5010, 5011, 5022, 6000, 6003, 6005, 6020, 6029, 7015, 7016, 7022, 7024, 8004, 8016, 8017, 8023, 9005, 9007

The calculated temperature of the outer covering layer for winter conditions is -20° C. The calculated temperature of the internal covering layer for heated rooms is +20° C, and -30° C for freezers. A panel covered by matt colour (if shine does not exceed 10 units in line with EN 13523-2) absorbs much more solar energy than a panel with the same tone, but shinier.

1.1.2. Instructions for mechanical resilience calculations and assembly layout

The load-bearing capacity of wall and roof panels after taking into account tensions and deformations caused by temperatures shall be calculated for every building. The calculations shall be done in line with Eurocodes and the European Standard EN 14509. The designer of a building is responsible for the choice of the conditions for loads. The loads shall be calculated in line with Eurocodes.

The load-bearing capacity of TEXNAX sandwich panels is specified as the maximum relations between loads and span lengths. The guarantees provided by the manufacturer are valid only, if the load parameters are stated correctly and the load-bearing capacity of a panel is assessed in line with the instructions given by TENAX PANEL.

The load-bearing capacity of a sandwich panel is calculated in line with EN 14509 basing on the values provided by the declaration of performance. If the TENAX PANEL calculation values are not applied to the calculations of the load-bearing capacity of a panel, the manufacturer cannot bear responsibility for the suitability of the selected panel for the loading conditions.

If a covering layer by the group III colour or matt covering is selected, the maximum permitted length of a panel is:

- 9.5 meters for wall panels;
- 13.5 meters for roof panels.

If a panel covered by the group III colour or matt covering is selected and it exceeds the stated length, the manufacturer's general guarantee is not valid. To maintain the guarantee, written approval for the suitability of a panel for the particular use must be received from TENAX PANEL.

A colour tone influences the load-bearing capacity of facade panels with two or more span lengths (multi-span panels) to a much higher degree than that with one span. Multi-span panels with group III colour tones develop higher tensions and deformations than panels covered by group I colour tones.

The designer of a building shall take into account the limitations to the load-bearing capacities at the design stage by providing the relevant assembly layout (single span / multi-span), panel length, colour and other conditions for panels influencing the limits for the load-bearing capacities (ULS) and the applicability (SLS) of a panel, or the used framework layout shall be changed. For example, the provisions for deformation and tension can also be influenced by fasteners at a framework, openings cut into panels, deformation limiters, constructions appended to the panels, neighbouring panels with coatings of other colour groups, air and panel temperature during installation, etc.

If multi-span panels are subjected to different deformation schemes on one facade, the load/span relations published by the manufacturer cannot be applied. Given that real panel deformation schemes usually differ from the conditions used for calculations, the load/span relations published by the manufacturer for group III colour tones shall be tested additionally.

The manufacturer's guarantees for panels in a group III colour tone or with matt cover in a multi-span installation are valid only if the assembly layout has been approved by TENAX PANEL in writing, as well as assemblies and order are observed strictly in line with TENAX PANEL instructions.

For the provisions for installation of dark panels, see section 5.7.

1.1.3. Panels without surface profile or with V-type profile

Panels without surface profile or with V-type profile are permitted only for installation in one span assembly layout. To install these panels into a multi-span layout written approval from TENAX PANEL must be received.

1.2.Detailed elaboration

More detailed information about sandwich panel assemblies is given in the Drawing set "Assemblies" for sandwich panels. This instruction is applicable together with the relevant drawings and the documents referred to in the drawings.

1.3.Labour safety

All work with products should always be carried out in line with the current occupational health and safety regulations valid in the place of use.

The edges, corners and mechanically processed places are sharp, please use protective gloves and clothing. When processing panels mechanically, use safety goggles and ear protectors.

Sandwich panels are massive products. Follow the safety instructions for handling. Ensure that there are no people under a lifted panel. Strong winds can reduce the stability of the panel during lifting significantly. Do not install panels in windy conditions, if safety considerations are compromised. Lifting of panels is forbidden in strong winds (gusts exceeding 10 m/s).

Follow the manuals and safety instructions for the instruments, equipment and devices used.

Follow the other particular occupational safety requirements at the construction site.

1.4.Nature protection

Utilise packing materials and working waste in compliance with provisions valid in the place of installation. Look after nature.

1.5.Responsibilities and guarantees of the manufacturer

This instruction contains essential information about the manufacturer's responsibilities and guarantees.

TENAX PANEL is responsible for the conformity of its products on condition that the manufacturer's all instructions are observed. TENAX PANEL is not responsible for damage, incl. the destruction of a product caused by the breach of the provisions specified in the manufacturer's instructions.

It is possible that the manufacturer's instructions and drawings do not provide solutions for all the potential cases. TENAX PANEL is not liable for losses caused by calculations or assemblies, or other technical solutions not approved by TENAX PANEL in writing.

Degradation of a product package, a siliconized paper tape, changes in the colour of the insulation interlayer in the course of time or foam residue on the internal metal surface in the case of a longitudinal overlap cut automatically on the production line (it must be cleaned fully before installation and it is the BUYER'S responsibility) are not deemed as defects.

TENAX PANEL is entitled to modify technical documents unilaterally. In all cases, the user shall use the edition of the document valid at the time the agreement is signed. Contact the TENAX PANEL sales representative in case of any uncertainty or doubt.

1.5.1. Tonal consistency

In order to characterize a tone of painted steel, RAL colour code system is used most widely. The human eye can differentiate among various tones of colours within the range of one colour code (for example, RAL9001). The ability to differentiate among the tones of colours is very individual. The lighter the colour, the clearer the tonal differences. Tonal and shine differences are also discerned more easily for metallic tints.

TENAX PANEL guarantees tonal consistency for its PRODUCTS on the basis of the guidelines for tonal consistency issued by ECCA (European Coil Coating Association), which are expressed as "ΔE" CIELab colour co-ordinates. The BUYER is responsible for the choice of colour shade appropriate to the construction design and the interests of a client ordering a construction / a site.

Table 2. The limiting values for tonal consistency from "Colour assessment of prepainted metal: ECCA guidelines"

Tonal categories		RAL examples ¹	CIELab ²		Allowances ³
Category 1	Very light	9001, 9002, 9010, 9016, 9106	L* > 80 and C* ≤ 10		ΔE ≤ 1.0
Category 2	Light	1015, 1202, 7032, 7035, 7501, 9073	L* > 80	10 < C* ≤ 20	ΔE ≤ 1.3
			60 < L* ≤ 80	C* ≤ 10 C* ≤ 25 and 11 < a* < 11 and 5 < b* < 25	
Category 3	Dark	1019, 3005, 3009, 5008, 5014, 6003, 6300, 7016, 7022, 8011, 8012, 8014, 8017, 9005		L* > 80	20 < C* ≤ 30
			60 < L* ≤ 80	C* ≤ 30 and - 16 < a* < 16 and - 5 < b* < 25	
				L* ≤ 60	C* ≤ 30
Category 4	Saturated	1002, 3000, 3011, 5002, 5010, 6029, 8004, 8701	L* > 80	C* > 30	ΔE ≤ 1.5
			60 < L* ≤ 80		
			L* ≤ 60		
Category 5	Metallic	9006, 9007	Unmeasurable		Visual control

1) The attribution of a tone to a certain tonal group is stated by the manufacturer of the painted metal.

2) Allowances applied, when 45/0°, 0°/45 and D/8° geometry is used for spectrophotometer measurements.

3) The manufacturer of metal may state different allowances for separate tones.

The specified tonal consistency criterions (ΔE limiting values) are valid only for the panels of category 1 (light), category 2 (medium), category 3 (dark) and category 4 (saturated) tones of colours for neighbouring panels on one facade or internal wall, or ceiling plane. For neighbouring panels installed in different facades or planes of internal walls (for example, two neighbouring

panels in a corner of a building), the tonal differences must not exceed the provided limiting values for more than two times.

According to ECCA classification, tonal consistency cannot be measured for panels with organic coatings in metallic (category 5) tones. The BUYER is fully liable for the category 5 tonal consistency of the installed product. For specific instructions for the installation of metallic tone panels, see section 5.8.

If different manufacturers supply elements for the surface covering of a construction/site (such as panels and gates), or it is planned to install the PRODUCT near already installed covering elements, the tones of these elements must be approved by TENAX PANEL before the confirmation of a PRODUCT order; for this colour samples must be submitted to approve the tones for the guarantees to be valid, so that shifts in tones in relation to the sample colour would not exceed the limiting values for more than two times.

In the event of disagreements, the difference in tones is assessed by measurements in line with the provisions of the standard EN 13523-3: 2014.

1.5.2. Corrosion resistance

Industrially painted steel received by TENAX PANEL from steel manufacturers is used for the production of sandwich panels. Therefore, TENAX PANEL guarantees for corrosion resistance do not exceed those received by TENAX PANEL from the painted steel manufacturers.

A client can receive special guarantees for corrosion resistance by sending a special request to the representative of TENAX PANEL before the approval of an order. Upon receiving such a request, TENAX PANEL will select the steel most suitable for the particular use and sustainability demands.

2. Transport and storage

2.1. Package

The surfaces of panels are covered by a self-adhesive film to protect them from scratches during transportation.

Panels are packed in stacks placed on ≥ 120 mm high foam polystyrene (EPS) supports and wrapped in polyethylene film. If a package contains panels of different lengths, the shortest panels are placed on the longest ones. The lowest panel of the package is covered by a EPS sheet and/or a timber pallet to protect the panel from damages during its transportation by a fork lift.

Every package of panels is accompanied by a labelling sheet, which contains the information about the order, the kind and sizes of the packed panels, as well as a sheet with manipulation signs and handling instructions.

At the client's request, slings for lifting by crane and distancer boards fastened by a sling at the upper and lower side of the package can be included and at the production site to the package. Packages shorter than 7 m have 2 slings included, but packages at least 7 m long have 4 slings.

The standard wrapping of packages is not suitable for transport in an open vehicle (headwinds can damage film wrapping during travel). A package can be adapted for transportation in an open vehicle, if a BUYER co-ordinates this with TENAX PANEL before the approval of the order.

For every order, the manufacturer plans the length and width of every package for optimal product delivery.

2.2. Panel supplies

The demands for a truck and actions during loading are provided by the document "Demands for Cargo Vehicles: Sandwich Panel transport" (available at www.tenaxpanel.lv).

During transportation, the panels must not touch the constructions of the cargo space, the neighbouring panels or the slings and fixation mechanisms. To protect panels, spacers are provided by TENAX PANEL at the handing over of the products in the factory.

Before unloading products, take photos of their condition in the cargo space (so that the state registration number of the vehicle, the content of the cargo after uncovering the tent covering the cargo space, if needed) before any further manipulations to the cargo is done. Check, if the number and sizes of the received panels correspond to those provided by the accompanying document. Make sure that the package and the products are not damaged before unloading from the vehicle and after they are unloaded. If a defect or another deficiency of a product is found, the received cargo must be photographed (so as to see all the relevant damages/deficiencies and the state registration number of the vehicle), and the defects and other information mentioned here must be written on the freight bill (CMR, delivery note – invoice), the entry must be made on all copies. The photographs together with the freight bill, where all defects are provided, must be sent to TENAX PANEL by e-mail immediately.

Make sure that the ordered and supplied additional consumable materials and fasteners are suitable for the framework of the specific building. Check if the supplied set corresponds to what was ordered.

2.3.Unloading of panels

2.3.1. Unloading of packages by lift trucks

Unloading of packages by lift trucks is appropriate only on a flat surface. Move at a speed appropriate to the cover.

Only one package of panels by a lift truck is allowed at a time. When two packs are lifted at a time, the bottom panel of the bottom package can be damaged due to the exceeded load at the forklift forks. Unloading

Soft, clean and smooth material must be placed between the forklift forks and the bottom panel of the package, for example, an EPS sheet added for this purpose at the factory, or a wooden pallet with an EPS sheet.

Do not push the forks too far behind the panel package, because the panel package located behind it can be damaged in this way, or, if the forks will not support the panel along all its width, the ends of a support can leave impressions on the panel surface. Special attention should be paid to this, when unloading 1.2 m wide panels.

Act very carefully to prevent scratches on the panel surface by the lifting mechanism of a forklift.

When forklift is used, the width of the supports must be at least 150 mm, and the support requirements as shown by the Table 1 must be followed.

2.3.2. Unloading of packages with a crane

When unloading the packages with crane, use slings with an appropriate lifting capacity. If the packages are ordered for unloading with a crane, use lifting slings which are included in the package in the factory:

- check whether the lift slings have not been damaged during transportation;
- the package is balanced, when lifted, and the slings have not turned;
- board distancers protect the panels from damage caused by slings.

The lifting slings shall be used only once, and they cannot be used to lift other loads.

Packages shall be lifted one by one. In order to prevent deformation of a panel use sufficiently long slings or use a traverse beam (see Figures 1 and 2). If a traverse beam is not used at the upper side of the package, the edges of the upper panel must be protected against the slings.

Figure 1. Lifting without a traverse beam, if the length of the package does not exceed 7 m.

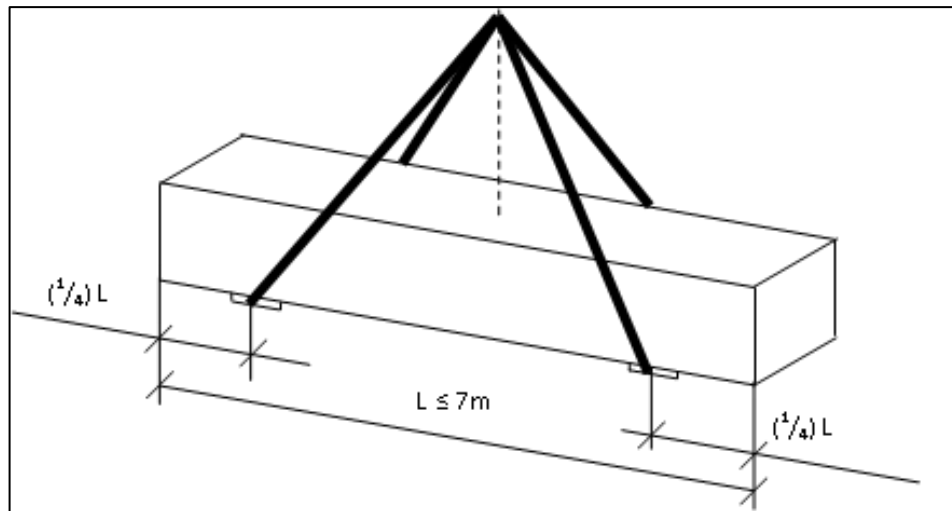

Figure 2. Lifting with a traverse beam, if the length of the package exceeds 7 m.

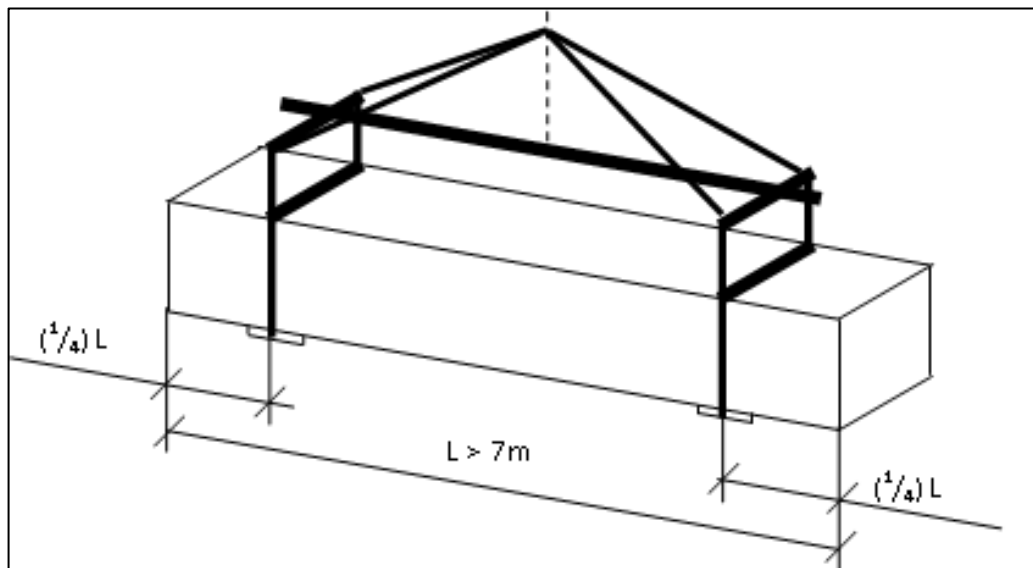

Table 3. Limitations to the transportation of panel packages

Type of panel	Thickness, mm	The maximum full length of panel package to be moved by							
		a lift truck				a crane			
		2 supports, m		4 supports, m		2 profiles, m		4 profiles, m	
		MW	PIR	MW	PIR	MW	PIR	MW	PIR
Wall panels (W)	50	4	9	6	11.5	3	6	6	11.5
	80	6	10.5	8	13.5	4	8.5	8	13.5
	100	6	12.5	8.5	14	4	9	8.5	14
	120	7	13	9	14	4	10.5	9	14
	150	7.5	14	9.5	14	5	11	9.5	14
	175	8	13.5	10	14	5	11.5	10	14
	200	8	13.5	10	14	5	13	10	14
	240	8.5	-	10.5	-	6	-	10.5	-
	300	9	-	11	-	6	-	11	-

Roof panels (TR)	40	-	7	-	9	-	7	-	9
	50	6	9	8.5	11.5	6	8.5	8.5	11.5
	80	7	10.5	9.5	13.5	7.5	11	9.5	13.5
	100	8	12.5	11	14	7.5	13	11	14
	120	8	13	11	14	8	13.5	11	14
	150	9	14	11.5	14	9.5	14	11.5	14
	175	9	-	12	-	8.5	-	12	-
	200	10	13.5	12.5	14	8.5	14	12.5	14
	240	9.5	-	12	-	9.5	-	12	-
	300	9.5	-	12	-	11	-	12	-

**The calculations are valid, if the width of the support is 150 mm for a lift truck*

***When unloading by crane, supports must be distributed evenly along all the length of a panel. TENAX PANEL can pack the panels together with lifting slings upon request.*

2.4.Storage of panel packages

Always place panel packages on a smooth and hard surface, where water does not accumulate. It is advisable to put a package at a suitable place for its storage at once to prevent repeated handling of panels. During storage, prevent personnel from walking on the surface of panels, because this can scratch the surface. Do not load other items on panel packages, this can damage a panel.

Panels must lie at least 100 mm over the storage surface during storage. Panels must be placed on supports or other panels so as not to exceed the industrial number of panels in one package, and no more than two packages one on another. If a package lacks some support provided industrially, it must be replaced by an equal support. The package must be distributed equally along all supports. The maximum distance between the supports during storage must not exceed that of the industrial package. A package must be placed slightly inclined (5 % at least) to let rainwater (or condensate in the case of storage under a cover) to flow off from panels.

When packages are stored one on another, their total height must not exceed 2.7 m. When placing in several layers, the foos of the packages must be placed along one vertical plane for the upper and the bottom package.

Due to continuous impact of solar radiation, the adhesion of the protective film of panels can increase, it can stick to the panel surface, and it can be harder to remove it, also glue stains can remain. Panels coated in dark tone can bend, when heated in the sun.

It is allowed to store panels in an open area without additional protection no more than for 4 weeks. If storage is planned longer, panels must be covered by a opaque and water resistant (at least 200g/m²) tent. A distancer for ventilation must be placed between a tent and a package (at least 30 mm wide). The tent must cover a package at least to the bottom of the lowest panel. The tent must be fastened mechanically so that wind could not lift it. For protection from snow during storage in winter, the covering of a package must reach its bottom (including the supportive feet). It is necessary to cover also the panels, which are unpacked or whose package is damaged.

Self-adhesive film must be removed, if panels are stored for more than 8 weeks. At least 3 mm thick foam polyester tapes shall be laid between panels to protect their surface from scratches and to provide conditions good for the coating of metal. This provision also applies to storage in rooms for longer than 8 weeks.

If the provisions for storage are not met, guarantees are not valid for the compliance of metal coating to the performance indicators as provided by the standard EN 13523, incl. shine of surface, tone differences, white rust, metamerism, also corrosion.

3. Preparations for installation

3.1.Devices and instruments

3.1.1. Lifting devices

Make sure you have all the necessary lifting tools and equipment which is in compliance with occupational safety requirements.

Calculate the lifting loads taking into consideration the weight of panel area and the area of a panel. The weight of panel area is provided by the performance declaration. The area of each panel is provided by the product label on every package.

Be aware that mechanisms and tools needed for lifting depend not only on the kind of a panel and on lifting technique, but also on the panel length. Observe the limitations to panel length for lifting.

For safe lifting and installation of separate panels mechanical or pneumatic grippers are needed. Use suitable gripping devices to avoid damages to panels.

Some examples of gripping devices are shown on Figure 3. Observe the instructions provided by the manufacturers of gripping devices.

Figure3. Examples of gripping devices

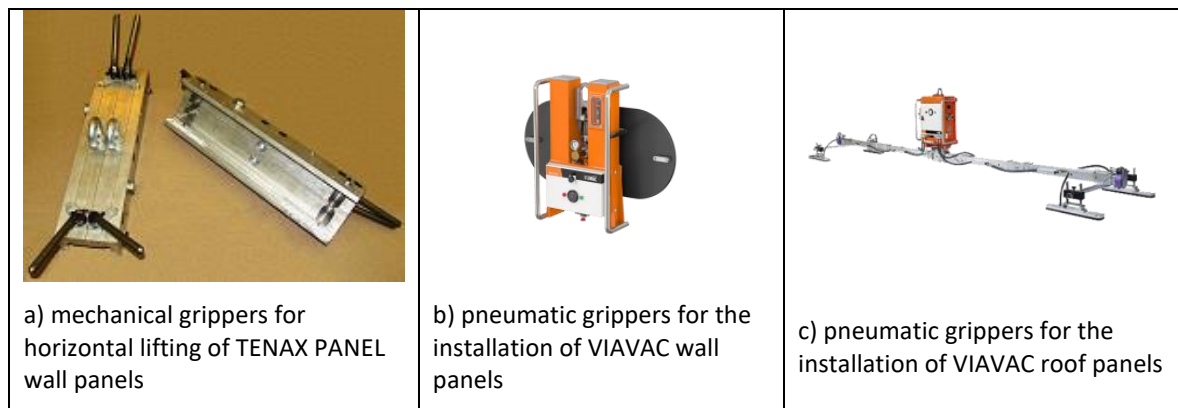

3.1.2. Tools

At least the following tools are needed for the installation of panels:

- a saw for steel sheet (see Figure 4);
- plate cutters (for flashings);
- screwing machine;
- rivet tongs (for flashings);
- drilling machine with appropriate drills for the respective framework;
- a knife for mineral wool sheet;
- a sealant gun.

At least the following measuring devices are needed for the installation of panels:

- a straight profile (1.2 meters) or a spirit level;
- a measuring-tape or laser distance meter ($l \geq 15$ m);
- a laser level meter.

Use a suitable fine-toothed jig saw or a circular saw with hard alloy blade to cut panels. It is forbidden to use cutting instruments, which are heating metal during cutting (such as angle grinder with an abrasive cutting wheel).

Figure 4. Examples of devices for panel cutting



3.2. Building framework

Make sure that the framework of a building corresponds to the demands given in the Drawing set “Assemblies”.

Make sure that the framework corresponds to the construction design.

Make sure that the framework of the building is sufficiently straight and smooth. To make a building leakproof and compact, joints between a construction and a sandwich must be panel leakproof and airtight. For airtightness and impermeability sealing tapes 3 mm (for steel constructions) and 6 mm (for reinforced concrete and concrete constructions) are used. The allowances of the constructions must fit in their ranges so that sealing tape would be compressed for at least 30 %.

Measure the straightness and perpendicularity of roof constructions.

Do not start to install panels before all non-conformities of framework are not prevented.

4. Lifting and moving of separate panels

4.1. General instructions

Separate panels may be moved only manually or by lifting devices.

When moving panels by lifting devices, use suitable mechanisms or pneumatic (vacuum) lifting devices. When lifting panels by lifting devices, safety slings are compulsory to prevent falling of a panel during movement.

Observe the instructions provided by the gripper manufacturers.

If the bottom metal of a panel contacts other smooth surface, it is obligatory to loosen the panel from it before lifting. Carefully push the panel to side in order not to scratch its metal coating at the cut sides of a panel.

Strength is reduced for panels with cuttings. Unified regulations cannot be set for lifting such panels. Before to cut panels at a construction site, make sure about the possibilities to lift and move such panels.

Be especially careful, when you lift the upper panel from a package to avoid damages to the panel under it.

4.2. Lifting and moving panels manually

Small size panels may be lifted and moved manually. A panel must be taken at the bottom side in such case. It is forbidden to lift a panel, while holding it by hands at the upper sheet of metal.

Use protective gloves and make sure not to damage panels. Special attention must be paid to the corners and edges of panels. When load-bearing panels manually, they must be hold vertically (see Figure 5). load-bearing panels horizontally is forbidden.

Figure 5. Moving panels manually

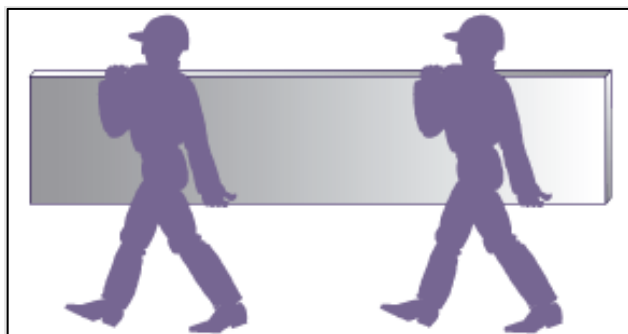

4.3. Mechanical grippers

Mechanical grippers are safe and economical choice, especially for lighter panels. When working at low temperatures, mechanical grippers can be the safest choice.

Inappropriately attached mechanical grippers can damage panels.

A panel must be moved from a package far enough to attach mechanical grippers safely. Precise positioning and screwing of a panel is possible only after removal of mechanical grippers. Provide a sufficient number of workers at a site to move a panel safely before and after lifting a panel by mechanical grippers.

Mechanical grippers can be ordered from the manufacturer of sandwich panels TENAX PANEL. For safe lifting of a panel use two mechanical grippers attached to a lifting beam. The limitations for horizontal lifting of wall panels by TENAX PANEL sandwich panel grippers are provided by the Table 2.

Table 4. The length limitations (m) for horizontal lifting of wall panels by TENAX PANEL sandwich panel grippers

SP thick, mm	50	80	100	120	150	175	200	240
Tenax W MW	8.5	9.5	11.0	11.0	10.4	9.4	8.4	7.4
Tenax W PIR/PUR	11.5	13.0	13.0	13.0	13.0	13.0	13.0	n/a

Mechanical grippers for vertically installed wall panels can be made at the construction site. For example, a U-profile with lifting loop of an appropriate size and resistance suitable for the particular panel can be used. A U-profile of a length approximately equal to the weight of the panel is pushed onto the end of the panel and fixed by at least 4–6 penetrating panel installation screws. The screws meant for lifting must be screwed so as to be insulated and covered after the installation of the panel. Length limitations to vertical lifting of wall panels by a U-profile of appropriate resistance and 4–6 installation screws depending on load-bearing capacity.

Table 5. The length limitations (m) for vertical lifting of wall panels by TENAX PANEL sandwich panel grippers

SP thick, mm	50	80	100	120	150	175	200	240
Tenax W MW	4.0	5.7	6.6	7.2	7.8	8.0	7.6	6.4
Tenax W PIR/PUR	9.0	11.0	12.0	13.0	13.0	13.0	13.0	n/a

Usually, it is most convenient to lift facade and roof panels using vacuum lifting equipment. When selecting the kind of pneumatic gripper, panel deformation during lifting must be taken into account. The length limitations for lifting panels by pneumatic grippers are provided by the Tables 4 and 5.

Remove protective film from the panel before to lift it by pneumatic grippers.

Table 6. The length limitations (m) for lifting panels by pneumatic grippers

SP thick, mm	50	80	100	120	150	175	200	240	300
Tenax W/TR MW	4.6	5.8	6.6	7	7.8	8.2	8.4	8.6	7.6
Tenax W/TR PIR/PUR	8	9.6	11.4	12	13	12.4	12.2	n/a	n/a

A pneumatic gripper is placed in the middle of a panel (½+½)

Table 4. The length limitations (m) for lifting panels by pneumatic grippers for vertical installation

SP thick, mm	50	80	100	120	150	175	200	240	300
Tenax W MW	6.3	8.6	9.9	10.7	11.5	12	11.8	10.7	9.3
Tenax W PIR/PUR	11.5	13.5	13.5	13.5	13.5	13.5	13.5	n/a	n/a

A pneumatic gripper is placed at 1/3 from the end of a panel (2/3 +1/3)

5. General rules for installation

See more detailed information in the Drawing set “Assemblies”.

Comply with legislative requirements in relation to occupational safety, which are applicable in the place of use.

Before installation, make sure that the support framework is clean and dry. If necessary, clean the support framework so that sealing materials would stick to the surface of supportive construction.

Panels insulated by mineral wool must be protected from precipitation during installation. In case of precipitation all unfinished horizontal installation joints must be covered by a film (or other kind of waterproofing) to prevent water from penetration into heat insulation layer. Disregarding these rules deteriorates essentially the heat resistance of a panel, increases the risk of corrosion and decreases its lifetime.

If a defect of a PRODUCT is found during installation, the BUYER must stop the installation of the PRODUCT till the moment, when written instructions are received from TENAX PANEL about further actions. The BUYER must inform TENAX PANEL about the defect immediately, but not later than 2 (two) working days or by electronic mail, providing the description of the defect and appending photographs substantiating the defect. A PRODUCT with defects must not be installed in any case, otherwise all costs, including those related to the installation/dismantling are covered by the BUYER. Before it is handled in any way, as well as prior to assembly, it is the BUYER'S duty is to make sure the PRODUCT does not have any visual defects.

As for any product, a sandwich panel has its production and installation allowances; as a result of which the covering width of the sandwich panel may differ from the nominal width on a facade. Especially for vertical installation and horizontal installation (for high buildings) panel joints can shift from the planned, when allowances are summed, so the total covering width must be assessed and taken into consideration during further installation.

5.1. Mechanical processing

Any metallic chips from the place of cutting or drilling must be cleaned away immediately after mechanical processing.

5.2. Interruption/prevention of thermal bridging

When the internal covering layer of a panel crosses environment with different temperatures, this metal sheet will function as thermal bridging. Such situation is developed, for example, in the internal and external corners of a building. Where possible, thermal bridging must be stopped or its development must be prevented.

Thermal bridging is stopped for an external corner by cutting by a cutter and removing the internal covering layer metal from the end of the relevant panel. This must be done before the installation of the panel. In all cases make sure that the cutting of the covering layer does not influence the endurance of the panel fasteners. Special attention must be paid, when thermal bridging is interrupted in console panels, for example, in roof overhangs and parapets not to exceed the load-bearing capacity. The maximum depths for the interruption of thermal bridging in console panels is 4–5 mm.

For detailed instructions, see the Drawing set “Assemblies”.

5.3. Sealing of joints and places of fasteners

In order to exclude the movement of air and water vapour in air through the joints of panels, they must be closely connected. Gaps are not permitted between panels.

In order to make the construction compact and to prevent the penetration of atmospheric air and rain into a building, the joints between panels and places of fasteners must be sealed.

Joints must be sealed with the sealants and insulation materials as specified in the Drawing set "Assemblies". Make sure in all cases that the relevant heat insulation is not compressed and it functions.

Make sure the surface is clean and dry before the application of sealers. Surfaces must be cleaned if needed. Sealant must be applied to a joint evenly, without interruptions. Observe the rules for use provided on the packages and in the data sheets of the sealers. For the basic principles for sandwich panel compaction and sealing, see Figure 6.

Figure 6. Sealing and strengthening of sandwich panels

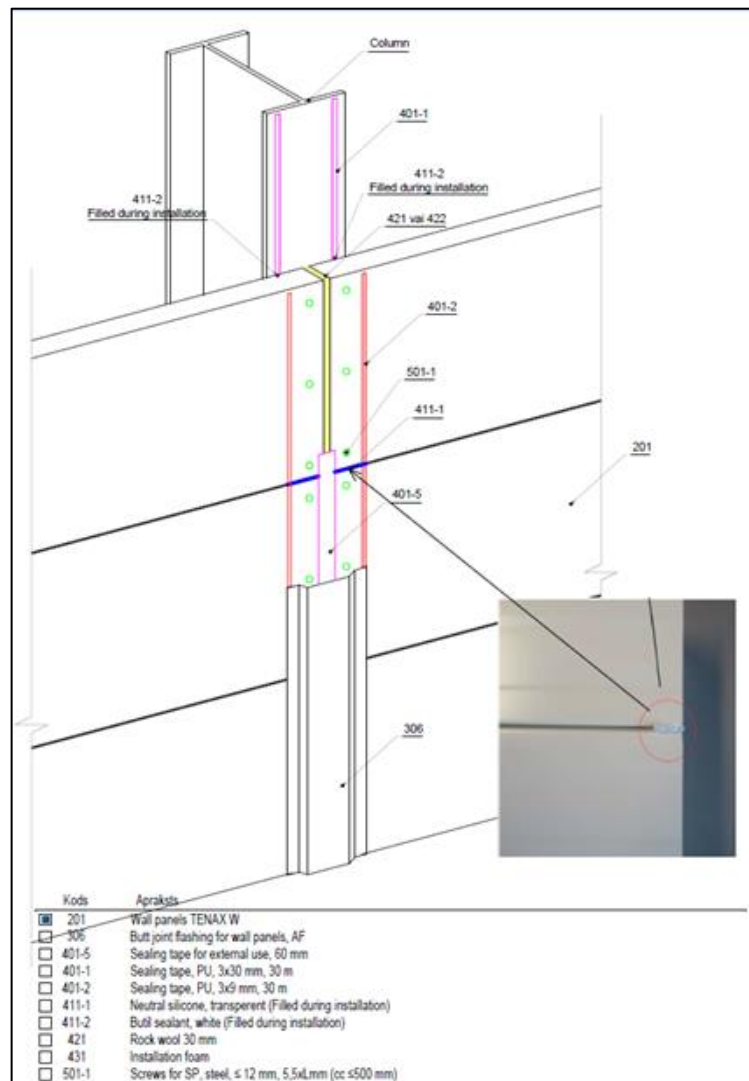

5.4. Attachment

Sandwich panels are fixed horizontally, vertically or diagonally at framework made of metal, concrete or timber.

Detailed instructions for installation are given in the Drawing set “Assemblies”.

Depending on the material of the framework, panels are fixed as given in the Drawing set “Assemblies”.

Observe the demands for the distances from the sides of panels and the sides of framework, as well as the depths of fasteners given in the Drawing set “Assemblies”. The maximum distance of a fastener from the side of a panel is stated by the selected width of a flashing detail, but no less than 30 mm.

In order to have a compact, waterproof joint, screws must be driven in perpendicularly into the panel surface.

When panels are fixed by screws, they must not be tightened too tightly or loosely (see Figures 7 and 8). It is advisable to use a screwdriver with a mechanism for torque control.

Figure 7. Tightening of screws on TENAX W sandwich panels with a standard key (side joint S or T)

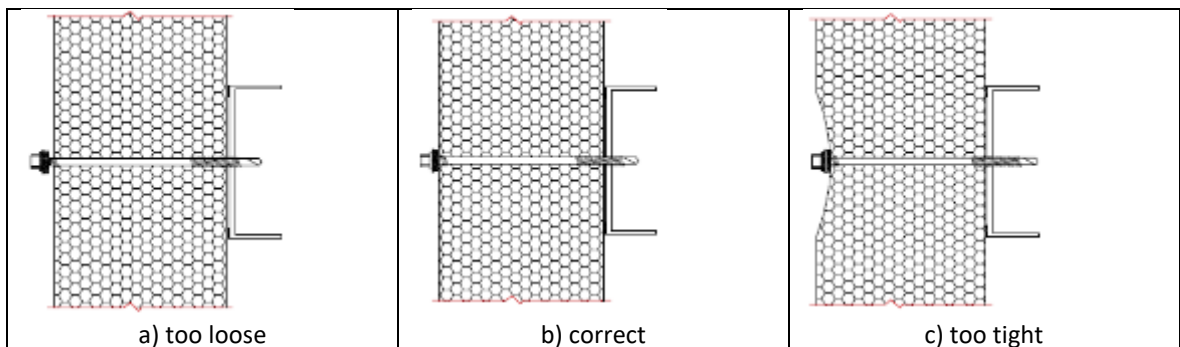
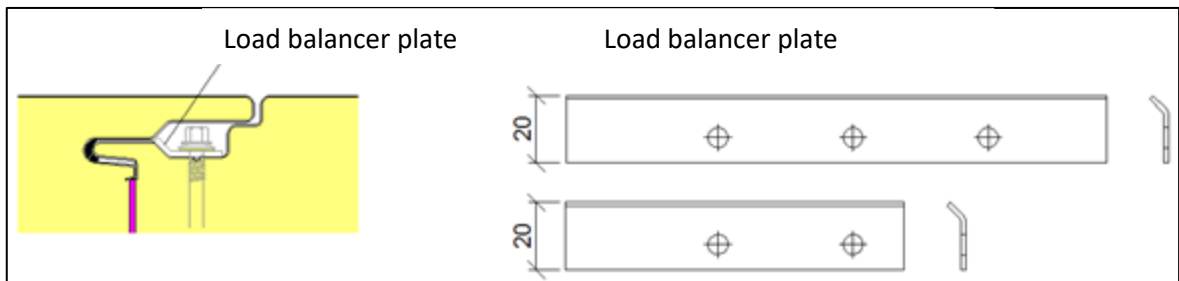

Figure 8. Tightening of screws on TENAX W sandwich panels with a hidden key (side joint H)



Use the number of screws defined in the project documentation.

5.5. Removal of protective film

The protective film shall be removed from the panel surface during the installation, but not later than in 8 weeks from the date of the supply of the panels. If this instruction is not observed, the removal of film from the surface of panel can become difficult.

Peel the protective film off every panel in one piece. Already before panel installation remove the protective film at the places of joints, fasteners etc. When vacuum lifting tools are used, remove the protective film before lifting panels.

To avoid leaving protective film strips or the remains of adhesive on the panel, it is recommended to remove the film in temperature range from 5 °C to +30 °C. The protective film peels off more difficultly and the remains of adhesive can be left on the panel, if the temperature is lower or higher.

5.6. Panel cleaning

If there are any glue or film residuals on the metal surface after removal of the protective film, choose one of the cleaning methods described below. Start with a cleaning method that has the smallest effect on the appearance of the sandwich panel. That is, start with method 1, and if this is not effective enough, move to the next option with larger effect on the appearance of the sandwich panel.

Warning! If there are any glue or film residuals on the metal surface, the cleaning should be done without any delay. The later the panels are cleaned, the harder it is to clean the panel.

To ensure that the cleaning method and agents are not damaging the panel, perform a test cleaning on a less visible and smaller area. Evaluate the test results under sufficient natural lighting after the panels have dried off.

Method 1. Water jet cleaning. To wash the sandwich panels, it is recommended to use clean water with low salt content and high-pressure water jet with pressure that is not higher than 4 MPa. By using a high-pressure water pump, keep the water jet at least 50 cm from the surface of the sandwich panel in a skew angle to it. When washing joints of the sandwich panels, make sure that the water is not entering into the joints. The water jet must not be aimed directly at the joint. Water temperature may not exceed +30 °C. If there are fats or grease on the surface of sandwich panels, water temperature may temporarily be increased to +50°C.

Method 2. Cleaning with cleaning agents. The surface may be treated with cleaning agents not containing organic solvents with pH level from 5 to 10.

Method 3. Cleaning with organic solvents. Permanent stains and residuals of the adhesive can be cleaned with isopropanol, white spirit, or ethyl acetate, or cleaning agents containing these solvents. In all cases, make sure that the solvent is not damaging the appearance of the metal covering.

- Use a sponge or a textile to wet the surface of the panel with a solvent.
- Scrape off the adhesive residues with rubber or plastic scraper.
- Clean the rest with soapy water.

Warning. Environment protection measures must be taken into account when using cleaning agents and solvents.

After use of a cleaning agent, the surface of sandwich panels must be immediately washed off with clean water. Sandwich panels should be cleaned from the bottom towards the top by thoroughly washing off cleaning agents from the top to bottom. Rainwater drains and drainage channels should also be rinsed.

It is not recommended to clean the sandwich panels with steam. Surfaces may not be cleaned with water, if the ambient air temperature is below or equal to 0 °C.

Surfaces with coating intended to be used in contact with food (for example, FoodSafe coatings) may be washed with cleaning agents not containing solvents with pH value from 5 to 8.

To avoid uneven visual image of a facade, it is advised to wash the whole facade.

5.7.Provisions for the installation of dark panels

Panels with dark coating must be protected from permanent impact of solar radiation during installation. If one side of the panel is heated, it can deform. The installation of deformed panels is difficult. Installation at temperatures below 10°C is not recommended. When panels are deformed, a wall or a roof can have essential visual defects. TENAX PANEL does not guarantee the flatness of a surface for dark panels fixed at the temperature below 10°C.

5.8.Provisions for the installation of metallic colour panels

During the process of manufacturing steel sheets, the beginning and the end of the roll can have tone differences, which are corresponding to the quality requirements, but can be discerned by the human eye. To avoid tonal inconsistency on the constructions to the maximum possible extent, the order of installation must be planned by the order of production (the numbers of packages), what is especially important for metallic tones.

As much as possible, the BUYER must select panels for installation according to the order of their production, panels must be installed in a row for each span of the framework (instead of layers), the appropriateness of tones must be assessed for every span of framework after the removal of the protective film, and the results of control must be documented in quality control entries.

6. Installation of external wall

6.1. Horizontal installation

Always follow the erection scheme for building and start the installation with the bottom panel.

Perform the horizontal fixation of panels to the external wall framework as follows.

1. Apply waterproofing and sealing tape to foundation.
2. Place the supportive profile at the given distance from the frame (column). Level the supportive profile so that the deviation of the supportive profile from horizontal does not exceed ± 3 mm per panel length. Fasten the supportive profile to the foundation.
3. Fill the support profile with insulation material as given in the instructions for assemblies.
4. Fix the plinth drip nose (if assembly of the drip nose is to be done before assembly of the panel). Ensure at least 10 cm overlapping of linear plinth drip noses. Apply sealant to overlaps.
5. Attach the sealing tape to the vertical framework. Ensure that sealing tape has adhered firmly to the framework, its surface is even and without interruptions.
6. Remove the protective film from the panel at place of joints and where the fasteners will be inserted, as well as in the places for vacuum lifting mechanisms, if you perform assembly with vacuum lifting mechanisms.
7. If necessary, perform panel machining (for example, elimination of thermal bridge at outside corner of the building).
8. Before the installation of every panel apply sealant to the joint according to the instructions for the assemblies to achieve a compact installation joint.
9. Fix appropriate lifting tools and safety line to the panel. Handle the panel according to the direction of installation.
10. Remove lifting tools and fix panel to the framework by using temporary fastenings (for example, a fix grip, if it does not cause any mechanical damage to the panel). Check the position of the panel, i.e. whether the support width of the panel on the framework is sufficient. The support width shall be at least 50 mm on the end support and 60 mm on the internal support.

Instruction: Check with a manual or laser level, whether the deviation of the panel from horizontal does not exceed the limit ± 3 mm per length of the panel.

11. If the panel is positioned correctly, while the temporary fastenings are not released, fix the panel permanently to the framework. Use the fasteners given in the Drawing set "Assemblies". Follow the instructions for the distances between screws, their depth and position.
12. Continue installation of the panels according to the installation scheme. Always apply sealant on joints before installation of the next panel in order to ensure joint tightness as provided by the instructions for assemblies.
13. When installing the panels in the next span, place panels in a way that the necessary gap between the panel ends on vertical support of the framework is as wide as required.

Attention! Panels are manufactured so as to establish a compact joint after their joining. Under the impact of temperature fluctuations, panels with hidden keys can cause the situation, when the panel must be pressed into the joint by a slight additional load to make the joint close. In this case loading must be done

carefully to avoid mechanical damages. Use the tool for the compression of plates together, see the example in the Figure 9.

Figure 9. The tool for the mutual compression of plates



14. Apply the sealants and compaction materials to the installation joints as given in the Drawing set “Assemblies”.
15. Cover the places of fixation at the end of panels by flashing detail. Before the installation of flashing details, insert sealers into the flasher profile. Join flashers by at least 5 cm long overlap.
16. Install assemblies in accordance with the requirements specified in the Drawing set “Assemblies”.

6.2. Vertical installation

Installation shall always be carried out in accordance with the assembly layout of the building.

It is recommended to install the panels in direction as given in Figure 10.

10. figure. The recommended direction for vertical installation

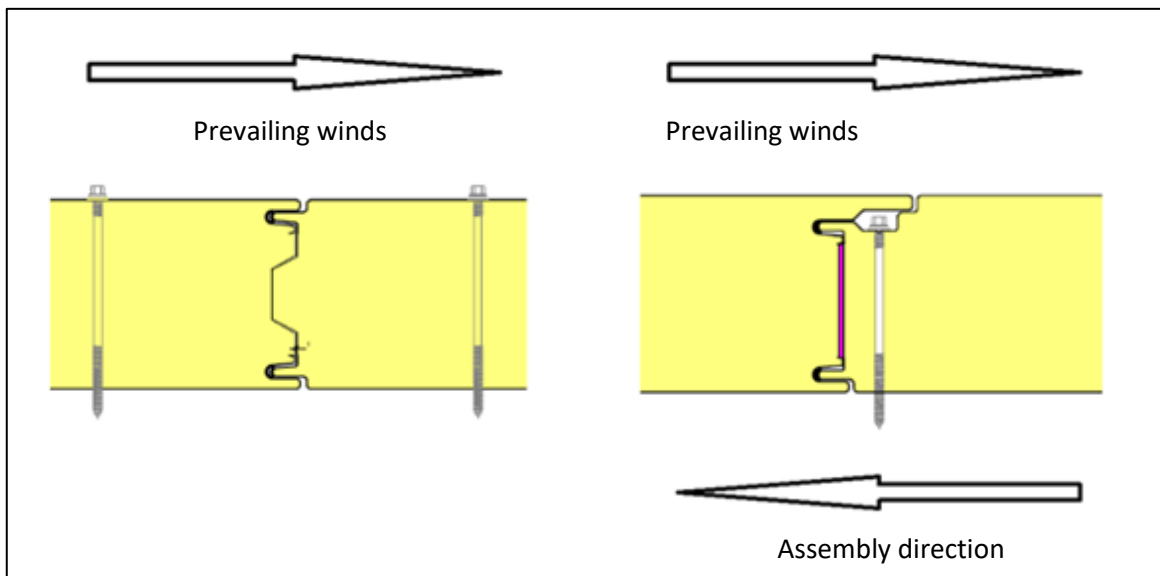

Perform the horizontal fixation of panels to the external wall framework as follows.

1. Apply waterproofing and sealing tape to foundation.
2. Fill the support profile with insulation material as given in the instructions for assemblies.
3. Level the supportive profile so that the deviation of the supportive profile from horizontal does not exceed ± 3 mm per 2 m. Fasten the supportive profile to the foundation.
4. Attach the sealing tape to the vertical framework to make the joint waterproof.
5. Apply the insulation materials on the basis next to the support profile as given in the instructions for assemblies.
6. Attach the sealing tape to the vertical framework. Ensure that sealing tape has adhered firmly to the framework, its surface is even and without interruptions.
7. Remove the protective film from the panel at place of joints and where the fasteners will be inserted, as well as in the places for vacuum lifting mechanisms, if you perform assembly with vacuum lifting mechanisms.
8. If necessary, perform panel machining (for example, elimination of thermal bridge at outside corner of the building).
9. Before the installation of every panel apply sealant to the joint according to the instructions for the assemblies to achieve a compact installation joint.
10. Fix appropriate lifting tools and safety line to the panel. Handle the panel according to the direction of installation.
11. Remove lifting tools and fix panel to the framework by using temporary fastenings (for example, a fix grip, if it does not cause any mechanical damage to the panel). Check the position of the panel, i.e. whether the support width of the panel on the framework is sufficient. The support width shall be at least 50 mm on the end support and 60 mm on the internal support.

Instruction: Check with a manual or laser level, whether the deviation of the panel from horizontal does not exceed the limit ± 3 mm per length of the panel.

12. If the panel is positioned correctly, while the temporary fastenings are not released, fix the panel permanently to the framework. Use the fasteners given in the Drawing set "Assemblies". Follow the instructions for the distances between screws, their depth and position.
13. Continue installation of the panels according to the installation scheme. Always apply sealant on joints before installation of the next panel in order to ensure joint tightness as provided by the instructions for assemblies. When fixing every next panel, the panels must be pulled together by a tool compressing the plates together, see the example <https://www.bohle.com/en-gb/products/handling-technology/fixing-aids/3298/veribor-seaming-tool-for-clamping-and-repositioning?c=13839> in the Figure 9.
14. When installing the panels in the next line (level), place panels in a way that the necessary gap between the panel ends on vertical support of the framework is as wide as required.

Attention! Panels are manufactured so as to establish a compact joint after their joining. Under the impact of temperature fluctuations, panels with hidden keys can cause the situation, when the panel must be pressed into the joint by a slight additional load to make the joint close. In this case loading must be done carefully to avoid mechanical damages. To compress the panels together, use the tool for the compression of plates together, see the example in the Figure 9.

15. Apply the sealants and compaction materials to the installation joints as given in the Drawing set "Assemblies".

16. Cover the places of fixation at the end of panels by flashing detail. Before the installation of flashing details, insert sealers into the flasher profile. Join flashers by at least 10 cm long overlap.
17. Fix the plinth drip nose. Before fixing the plinth drip nose, seal the horizontal joint by sealing tapes and sealer. Ensure at least 10 cm overlapping of linear plinth drip noses.

Attention! Rainwater flows down the vertical panel joint during rain, so rainwater must be led away from the horizontal joints and prevented from penetrating into the wall construction.

18. Install assemblies in accordance with the requirements specified in the Drawing set "Assemblies".

7. Installation of Profiled (Trapeze) Roof Panels

Installation shall always be carried out in accordance with the assembly layout of the building.

Panels should be installed in the direction as shown in Figure 11 by starting from cornice at the corner of a building.

Figure 11. The recommended direction for installation of profiled roof panels

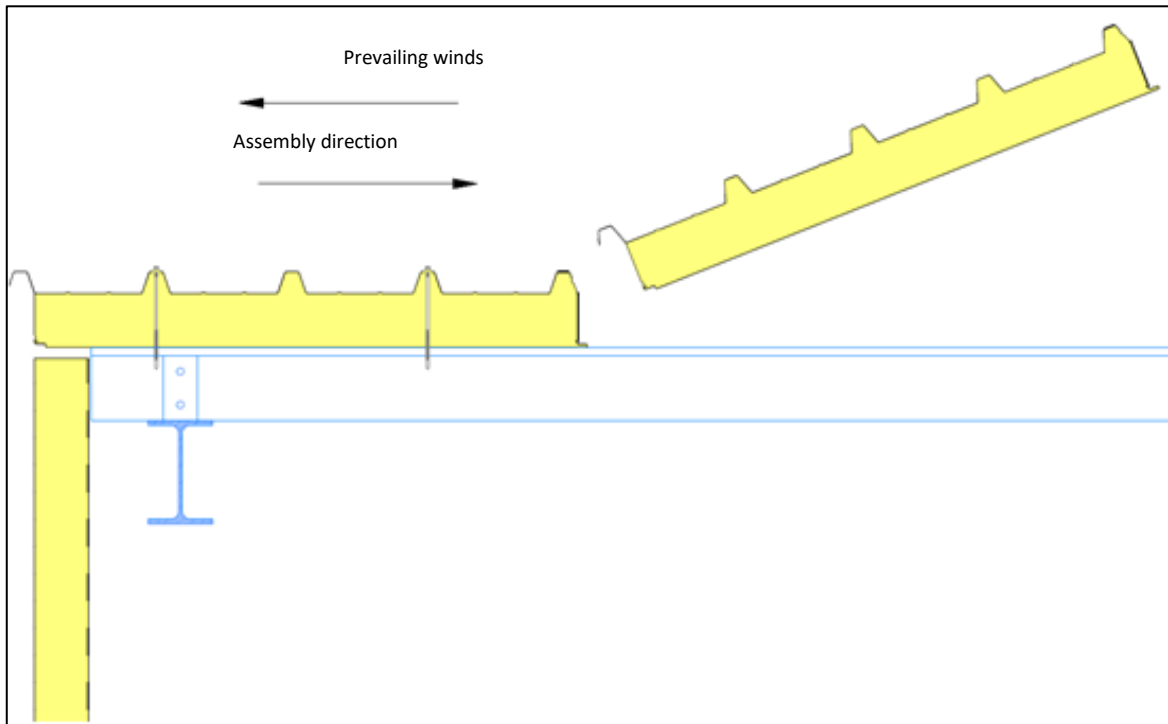

Attention! In order to ensure high-quality installation of sandwich panels, it is always recommended to use installation materials and parts supplied by the manufacturer of the panels.

Before the installation, assess visually the quality of the panels. If a defect is found in the panel, inform the manufacturer immediately.

During the process of manufacturing steel sheets, the beginning and the end of the roll can have tone differences, which are corresponding to the quality requirements, but can be discerned by the human eye. To avoid tonal inconsistency on the constructions to the maximum possible extent, the order of installation must be planned by the order of production (the numbers of packages), what is especially important for metallic tones.

Perform the horizontal fixation of panels to the external wall framework as follows.

1. Make sure that the load-bearing roof structures (beams, trusses, etc.) are assembled in accordance with the design documentation. Make sure that the roof slope is at least 5° (if the panels are joined on the slope) or at least 3° (if the slope is made of a single-span panel).

Attention! The application of panels in roof structures with uneven spacing between the support profiles on the roof span is not recommended. In such structures, the support profiles may cause unwanted deformation and leakage at the panel joints.

2. Before placing the panel, glue a sealing tape onto the first and last load-bearing profile. Attach the absorbing tape also on supportive profiles at the joining points of the panels, if overlapping is planned.
3. Place the sandwich panel in its intended position and remove the protective film from fastening points.
4. Screw the sandwich panel to the framework by the planned number of screws. Place the screws in every wave of the trapezoid with 250 mm step in the cornice and ridge of the building, in every support in the roof verge, in every other wave of trapezoid with a 500 mm step locating them alternately or according to the designers instructions. If the building is located in a windy area (for example, close to the sea), contact the manufacturer's representative to find the necessary number of fastenings. Use special screws and washers meant especially for this purpose, see Figure 12.

Figure 12. Fastenings for sandwich panels Tenax TR



5. If panels are divided and a penetrating cut has developed on one slope of the roof, install the panel closest to the cornice as the first, and the panel closing the row of panels at the ridge as the last.
6. Penetrating joints of panels shall be made in line with the solutions given in the Drawing set "Assemblies".

Attention! Strong wind flows may push water upwards against the roof slope. The smaller is the roof slope, the more attention shall be paid to sealing of the overlap joints. If the roof slope is small and the building is exposed to strong wind flows, overlap joints should be waterproofed additionally with special sealing tape.

Instruction: Please note that before lifting a panel onto the roof, the bottom coating and insulation steel layer shall be removed from the overlapping panel.

7. In the free edge of a sandwich panels (where the next row of panels will be installed) sealer shall be applied in line with the Drawing set "Assemblies".
8. Continue installation of the panels in each following row by starting from the cornice.
9. Connect the panels tightly. Fasten them together by screwing trough the panels and the load-bearing profiles. In addition, connect the lateral sides of the panel at the overlap areas

by using screws for steel sheets with a spacing of 500 mm (see the “Assemblies” detail design).

10. Carry out installation of ridge cap and cornice elements as well as any auxiliary materials along with the installation of the roof cladding in accordance with the solution shown in the “Assemblies” detail design.

8. Installation of Roll-Folded Roof Panels

Installation shall always be carried out in accordance with the assembly layout of the building.

Panels should be installed in the direction as shown in Figure 13 by starting from cornice at the corner of a building.

Figure 13. The recommended direction for the installation of roll-folded roof panels

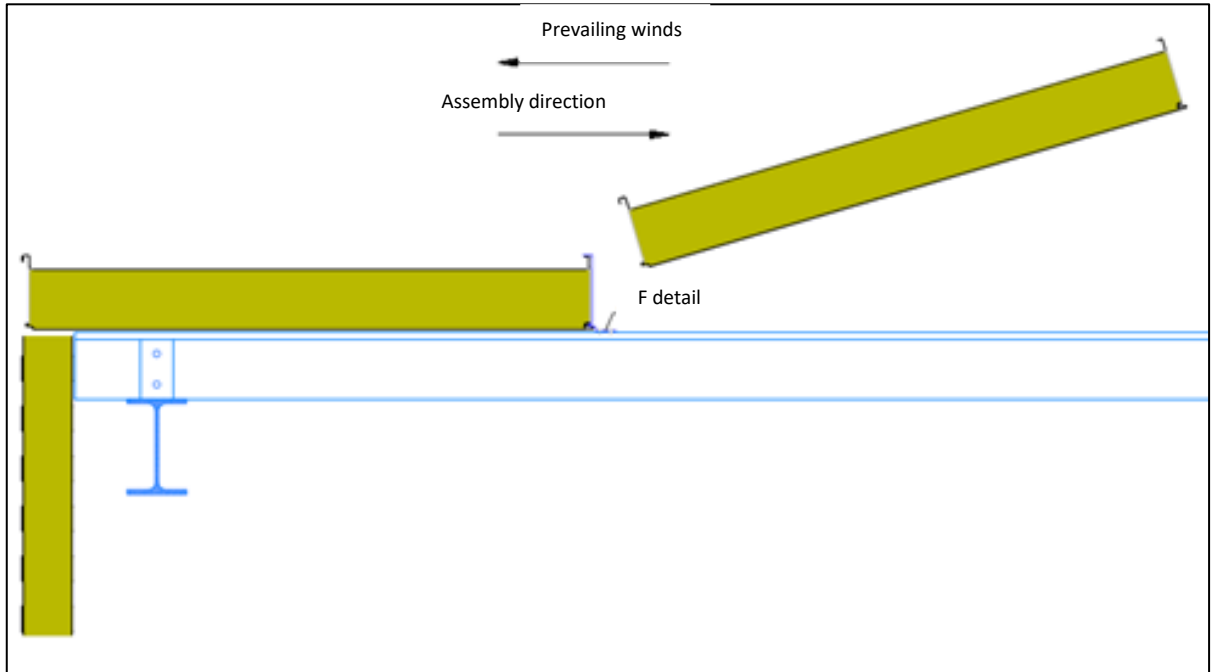

Attention! In order to ensure high-quality installation of sandwich panels, it is always recommended to use installation materials and parts supplied by the manufacturer of the panels.

Before the installation, assess visually the quality of the panels. If a defect is found in the panel, inform the manufacturer immediately.

During the process of manufacturing steel sheets, the beginning and the end of the roll can have tone differences, which are corresponding to the quality requirements, but can be discerned by the human eye. To avoid tonal inconsistency on the constructions to the maximum possible extent, the order of installation must be planned by the order of production (the numbers of packages), what is especially important for metallic tones.

Perform the horizontal fixation of panels to the external wall framework as follows.

1. Make sure that the load-bearing roof structures (beams, trusses, etc.) are assembled in accordance with the design documentation and suitable for the installation of sandwich panels. Make sure that the slope of the roof is no less than 3°.

Attention! The application of panels in roof structures with uneven spacing between the support profiles on the roof span is not recommended. In such structures, the support profiles may cause unwanted deformation and leakage at the panel joints.

2. In order to ensure complete joint tightness and waterproofness between the framework and the sandwich panel, absorbing tape before placing the panel.

Attention! Sealing tape shall be glued onto the support profile in a way that it is supporting the whole width of the sandwich panel, except for its fastening point! Sealing tape may neither be glued underneath, nor on top of the fastening parts.

3. Place the sandwich panel in its intended position and remove the protective film from fastening points.
4. Screw the sandwich panel onto support structure by using an appropriate amount of self-drilling screws. Screw the edge of the first panel which is placed along the wall of the building on each of the support profiles. At the cornice and ridge area, the panel shall be fixed to the support profile with 3 screws or according to the designer's instructions.
5. Sealant is applied and self-adhesive tape is glued on the free edge of a sandwich panel (where the next row of panels will be installed) according to the set of drawings "Units".
6. On its open edge, the sandwich panel shall be fixed to each of the support profiles with the JF fastening element and 2 rivets.
7. Each of the following panel rows shall be placed tightly next to the previous row.
8. Treat the areas that are going to be roll-folded with thick (viscous, non-leaking) lubricant that will provide an airtight joint after the panels are rollfolded.
9. Tighten the JF fastening elements together with the panels by using a particular roll-folding machine.
10. Penetrating joints of panels shall be made in line with the solutions given in the Drawing set "Assemblies".

Attention! TENAX R panel is not suitable for a longitudinal connection of a panel with another panel by an overlap.

11. Continue the installation of panels in every next row. If there is no factory-made rubber sealing strip or sealing tape on the lateral (longest) side of the panel at the joint area, apply a sealant or sealing tape before installation of every following panel in accordance with the "Assemblies" detail designs.
12. Carry out installation of ridge cap and cornice elements as well as any auxiliary materials along with the installation of the roof cladding in accordance with the solution shown in the "Assemblies" detail design.